

G & P ABRASIVE BELT PLATEN GRINDERS

BULLETIN PL-200

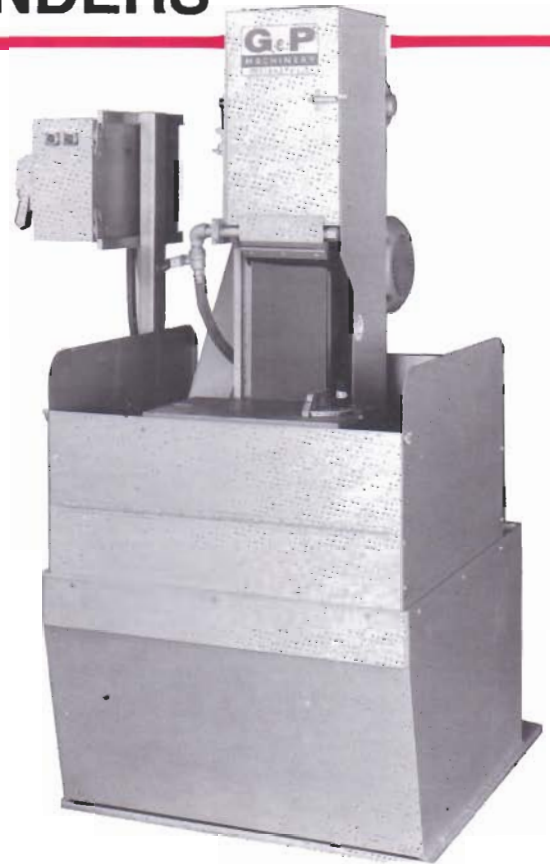

Never operate grinding equipment without proper guarding.
Always wear eye protection.

G+P
MACHINERY

WET/DRY PLATEN GRINDING



MODEL 8107-10 WV For Wet Grinding

SPECIFICATIONS FOR 8107-10

Abrasive belt size	8" x 107"
Abrasive belt speed	5500 SFPM
Type of belt tension	Air
Motor	10 H.P. TEFC 230/460/3/60
Starter	NEMA 12-230 or 460/3/60 with 115 volt at P.B.
Drive Pulley	10" dia. x 8" face Rubber Covered
Idler Pulley	10" dia. x 8" face Rubber Covered
Platen	Steel - 8" x 16" Hardened Tool Steel Optional Water Cooled Optional on Model 8107 - 10 DV only
Table	12" deep, 20" wide with angle adjustment
Table Height	40½"
Dimensions - Approx.	75" high, 48" wide 47" deep on Model 8107-10 WV 75" high, 29½" wide 40" deep on Model 8107-10 DV
Exhaust Outlet	6" dia. Model 8107-10 DV only
Coolant System	21 gal. capacity Model 8107-10 WV only

Specifications subject to change without notice.



MODEL 8107-10 DV For Dry Grinding

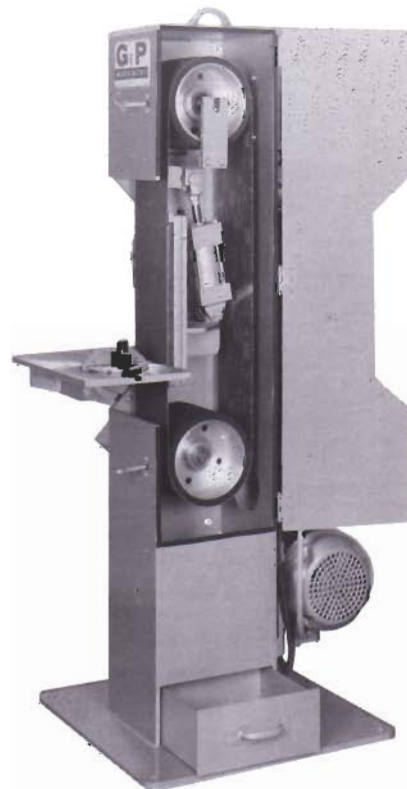

HORIZONTAL OR VERTICAL PLATEN GRINDER

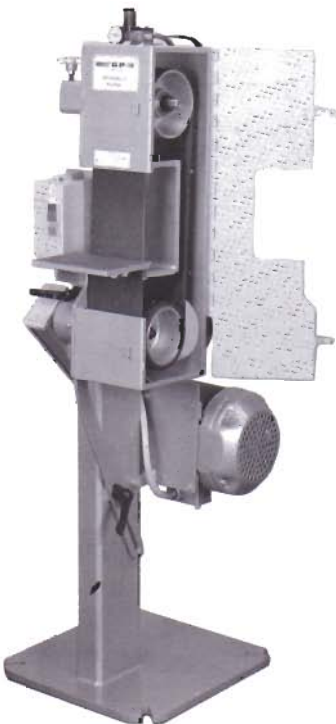

SPECIFICATIONS FOR HV660-D & HV860-D

	Model HV 660-D	Model HV 860-D
Abrasive belt size	6" x 60"	8" x 60"
Abrasive belt speed	5500 SFPM	5500 SFPM
Type of belt tension	Air	Air
Motor	2 H.P., 3 H.P. or 5 H.P. TEFC 230/460/3/60	5 H.P. TEFC 230/460/3/60
Starter	NEMA 1 Magnetic Full Voltage 230 or 460/3/60	NEMA 1 Magnetic Full Voltage 230 or 460/3/60
Drive Pulley	6" dia. x 6" face Rubber Covered	8" dia. x 8" face Rubber Covered
Idler Pulley	6" dia. x 6" face Aluminum	8" dia. x 8" face Rubber Covered
Platen	Steel - 6" wide, 10" long Hardened Tool Steel Optional	Steel - 8" wide, 10" long Hardened Tool Steel Optional
Table	6" deep, 8" wide Angle adjustment when grinder in vertical position. In horizontal position table serves as Cross Fence	6" deep, 10" wide Angle adjustment when grinder in vertical position. In horizontal position table serves as Cross Fence
Overall Height	62"	62"
Table Height	40 3/4" when grinder is in vertical position	40 3/4" when grinder is in vertical position
Platen Height	37" when grinder is in horizontal position	37" when grinder is in horizontal position
Base Plate	20" square	20" square
Exhaust Outlet	6" dia.	6" dia.

Specifications subject to change without notice.

Modifications and Special

Accessories Available

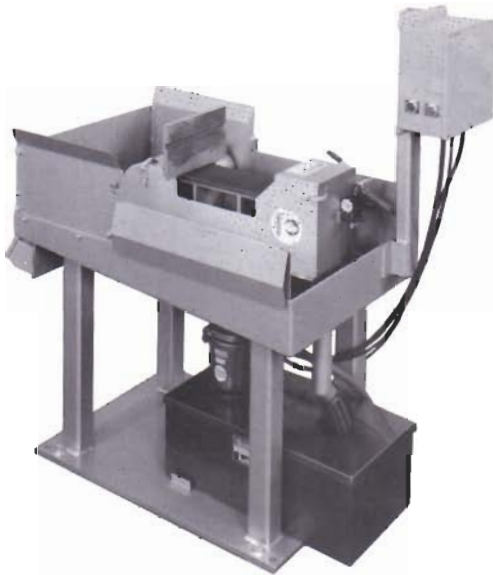

MODEL HV 660-W

These pictures show a model HV 660-W for wet operation including a coolant pump, reservoir and flood nozzle.

MODEL 8107 WV

These photos show an 8107-10 WV modified to a 8107-30 WV with a 30 horsepower motor and with a horizontal fixture mounting table with hydraulic movement on two axis.

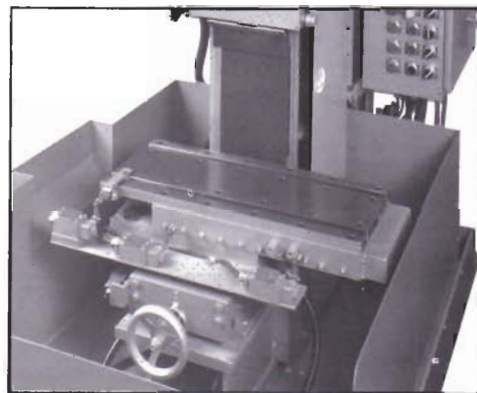
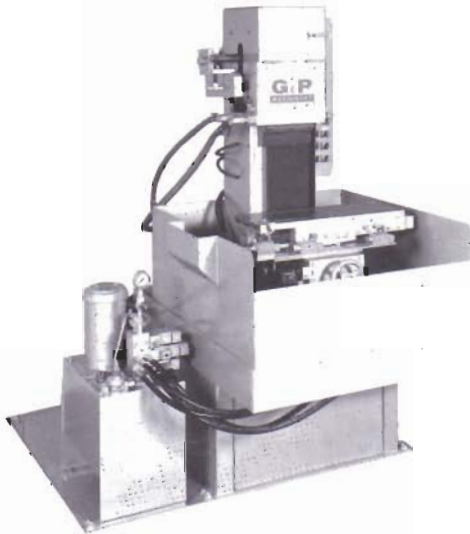

GRINDING & POLISHING MACHINERY CORPORATION

2801 TOBEY DRIVE / INDIANAPOLIS, IN 46219-1481

PHONE (317) 898-0750 FAX (317) 899-1627

G+P
MACHINERY

Printed in U.S.A. 02/03/94